



12/31/2021 - A Bi-Annual Newsletter by Trench Drain Contractors of America (www.TDCoA.org)

Laundry Trough Design

Be sure to comply with all codes. We would like to tell you there is a specific and simple procedure. Though we can provide pointers, your judgement will be required.

Our experience has been that the drain manufacturer will request the specific capacity(s), model number(s), and number of extractors connected to the drain trough. Then the laundry trough manufacturer wants to design the trough drain. This is the best scenario. Unfortunately, workflows typically do not allow for this. Under most circumstances you must design the laundry trough yourself.

Calculations:

- Dry laundry will absorb approximately 80% of its weight in water. I.e., 1.0 pound of laundry will absorb approximately 0.8 pounds of water and extractors are typically selected and sized by pounds of laundry. The figure for dry laundry is typically be listed by the extractor manufacturer.
- Though in reality some moisture is retained by the material when wrung out. And this moisture is in turn evaporated by the dryer. For our purposes this will be ignored.
- 1 Gallon of water weighs 8.33 pounds.
- 1 Cubic foot will hold 7.48 Gallons.
- A typical extractor size is 40 pounds which equates to $(40 \times 0.8 = 32)$ 32 pounds of water. 32 Pounds of water $(32 \text{ pounds} / 8.33 \text{ pounds/gallon} = 3.84 \text{ Gallons})$
- A typical extractor width is 36". Assume 36" of trough length per extractor.
- Of the 36" available remove 12" of length for installation of a lint screen. Then assume the drain trough runs 30% full.
- $36" - 12" = 24"$ in length.
- Assume 12" in width
- $10" \times 40\% = 4"$ in height.
- $24 \times 4 \times 12 = 1152$ cubic inches.
- 1152 cubic inches divided by 1728 cubic inches per cubic foot = 0.667 cubic feet = 0.667 cubic feet * 7.48 gallons per cubic foot = 4.98 Gallons.
- A 4.98-gallon drain trough capacity is greater than the 3.84-gallon extractor capacity and the trough dimensions are acceptable.
- While the project is being constructed get extractor model number from architect and provide to drain trough manufacturer to have sizing checked.

Both ABS and Polypropylene troughs are available for installation. Polypropylene is more resistant to heat & chemical attack however is also more expensive. ABS is less expensive and will provide long service in most laundry installations.

Unless temperatures above 180° F. or chemical attack "sours" is expected use ABS.

If you have any questions, please email us at the following address: wbonafe@TDCoA.org



12/31/2021 - A Bi-Annual Newsletter by Trench Drain Contractors of America (www.TDCoA.org)

Sours are most used in hotels or other locations as a fabric softener. Because they are in the final rinse they can sit in the trough for extended periods. ABS is subject to deterioration due to the use of sours acid, polypropylene is not.

Polypropylene is only recommended for laundries that are using “sours”.

Some sours are less acidic and won’t cause a problem. Some locations are careful to run another rinse through the trough after they are used. In most cases, ABS works fine.

The downside to polypropylene is that it is not a rigid plastic so if care is not taken during installation to assure it is fully supported, it can sag and crack which will cause it to leak. It must be heat welded so there is no way to repair it in the field and they often must be replaced.

ABS is structural so it can easily be shimmed for slope and won’t sag. It also has solvent adhesives and epoxies that bond it so if a leak were to develop it can be repaired.

Extractor discharge

Extractor drain discharge is usually single around 3” or 4” in diameter and is usually 4” to 5” above the floor. Be sure there is enough room to make necessary connections. If not otherwise known leave 12” from the drain trough to the extractor for drain piping connection.

40 #	
Drain Diameter - in (mm)	1 @ 3 (76)
Drain Height to Floor - in (mm)	4 13/16 (122)

Example of typical forty (40) pound extractor information.

Laundry Trough Installation

Laundry troughs are typically specified or detailed to be recessed and this requirement can typically be met, however, if you are a designer, a recessed installation may not be the best for your client. A recessed laundry trough is difficult to both maintain & install. Above floor installation will make it easier on the contractor thus saving installation dollars and on top of that it will be easier for the owner to maintain. Extractors are connected to the laundry trough using a UNISEAL© fitting of size to match extractor discharge pipe size.

Laundry Trough Custom Design

We have seen custom designed laundry troughs. The trough is formed in the concrete floor with a solid or grated top (usually cast iron or steel solid diamond plate) with a floor drain in one end and a custom designed lint filter (usually stainless steel or aluminum) between the washer discharge and floor drain.

If you have any questions, please email us at the following address: wbonafe@TDCoA.org



12/31/2021 - A Bi-Annual Newsletter by Trench Drain Contractors of America (www.TDCoA.org)

This should be avoided because it cannot be easily replaced, is difficult to maintain, may and the lint filter is usually a guess. If you are a designer specification of a manufactured item is far superior as it is easier to install, obtain, and is less expensive.

Soft mount vs. hard mount extractor (washer)?

If you are the designer of the drain trough this isn't really a consideration other than to coordinate with the support designed by the Architect/Structural Engineer. If you are the Architect, this is a concern because this decision impacts structural design. If you are the designer of the drain trough the definitions below are for your knowledge only.

What is a hard mount extractor (washer)?

A hard mount extractor (washer) is installed by bolting it directly to the floor, so it doesn't shake around. Typically, a steel or concrete floor to bolt the machines down is needed. If the owner does not already have a steel or concrete surface, a slab will be needed.

Hard mount extractors require a sturdy foundation because they don't have shock absorbers or springs to handle the vibration. Hard mount machines are usually required to be on the ground floor or basement of a building for this reason. The slab underneath must be solid otherwise the floors can crack, or the machine will cause damage to the building itself.

A concrete equipment pad approximately 4" thick and 4" larger all around than the extractor may be used. Consult Architect for installation details.

What is a soft mount extractor (washer)?

A soft mount extractor (washer) is installed by placing it directly into the floor. Shock absorbers and springs within a cradle will prevent it from shaking around. A steel or concrete floor not required to bolt the machines down. Soft mount extractors are easier to install, and they reduce vibrations.

Soft mount extractors are more expensive; however, the owner can save on cost with a soft mount option because they won't need to have a concrete slab poured or steel slab installed. Soft mount extractors aren't confined to basements and ground floors because of their shock absorbers.

A concrete equipment pad approximately 4" thick and 4" larger all around than the extractor may be used. Consult Architect for installation details.

If you have any questions, please email us at the following address: wbonafe@TDCoA.org

Trench Drain Specification

The best way to spell out what you want in terms of trench drains is to either use the specifications or the Plumbing Fixture Schedule / Detail on the drawings. Do not repeat information. Not only is that a bad use of your time it can be confusing for the contractor/supplier if there is conflicting or differing information.

What is important information to include?

A supplier needs channel material, grate width, material, configuration, and load class, drain number, location (End or Bottom), and size to provide a quote to the contractor. Drain number, location, and size are typically obtained from the plumbing drainage plan, drainage isometric, or drainage diagram.

The best way to spell out what you want in terms of trench drains is to either use the specifications or the Plumbing Fixture Schedule / Detail on the drawings. Do not repeat information. Not only is that a bad use of your time it can be confusing for the contractor/supplier if there is conflicting, differing, or missing information.

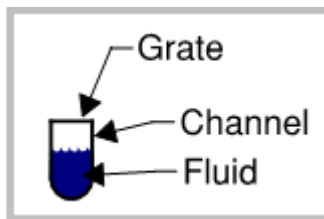

The channel material is important to include. Polyester concrete, glass reinforced polyester, stainless steel, high-density polyethylene (HPDE), PVC, or cast-in-place concrete (CIP) with a cast iron cover (grate) and frame, etc.

The grate or top can be of a different material than the channel. Cast iron, ductile iron, stainless steel, galvanized steel, or plastic of different load carrying capabilities. DIN Load Class *A, B, C, D, E, or F*. ANSI Load Class *Light Duty, Medium Duty, Heavy Duty, Extra Heavy Duty, or Special Duty*. The American Highway Association (AASHTO) *H20, or HS20*. The Federal Aviation Administration (FAA) *approval*.

Whether the grate must meet the Americans with Disabilities Act (ADA) requirements must be specified.

Indicate material, configuration, and load class. I.e. Galvanized steel, slotted, load class "C".

Ensure specified combination is available from a manufacturer because all combinations are not always available. I.e., there is no galvanized steel, slotted, load class "E" grate available from any manufacturer.

The best way to get what you desire is to provide a manufacturer, model number if available, width and grate and grate model number. End pieces & miscellaneous accessories for a complete installation should be specified but are typically provided by a reputable supplier.

A good source for information is www.trenchdrainsupply.com.



12/31/2021 - A Bi-Annual Newsletter by Trench Drain Contractors of America (www.TDCoA.org)

Trench Drain Capacity

We all know intuitively that any trench drain grate (other than a solid one) will have open area. We wonder how much water a Trench Drain Grate can handle. Here, we will attempt to equate Trench Drain Grate Open Area with pipe sizes for a rough estimate of water flow capability. We will share with you where we got pipe free area and flow capacity so you can judge for yourself how accurate this information is...

This article uses the formula for the area of a circle and the nominal pipe diameter $A = \pi * r * r$. I.e the area of a 6 inch pipe = $3.141592654 * 3 * 3 = 28.27$ square inches. GPM values below are from table 1-5 of the Plumbing Engineering Design Handbook "Plumbing Systems" copyright 2018 by the ASPE.

Table 1-1

Table 1-5 Approximate Inside Half-Full Flow Discharge Rates and Velocities for Sloping Drains, n = 0.015*								
Actual Inside Diameter of Pipe, in. (mm)	1/16 in./ft (5.2 mm/m) Slope		1/8 in./ft (10.4 mm/m) Slope		¼ in./ft (20.8 mm/m) Slope		½ in./ft (41.7 mm/m) Slope	
	Discharge, gpm (L/s)	Velocity, fps (m/s)	Discharge, gpm (L/s)	Velocity, fps (m/s)	Discharge, gpm (L/s)	Velocity, fps (m/s)	Discharge, gpm (L/s)	Velocity, fps (m/s)
1¼ (31.8)							3.40 (0.21)	1.78 (0.54)
1½ (34.9)					3.13 (0.20)	1.34 (0.41)	4.44 (0.28)	1.90 (0.58)
1¾ (38.9)					3.91 (0.247)	1.42 (0.43)	5.53 (0.35)	2.01 (0.62)
1⅞ (41.28)					4.81 (0.30)	1.50 (0.46)	6.80 (0.38)	2.12 (0.65)
2 (50.8)					8.42 (0.53)	1.72 (0.52)	11.9 (0.75)	2.43 (0.74)
2½ (63.5)			10.8 (0.68)	1.41 (0.43)	15.3 (0.97)	1.99 (0.61)	21.6 (1.36)	2.82 (0.86)
3 (76.3)			17.6 (1.11)	1.59 (0.49)	24.8 (1.56)	2.25 (0.69)	35.1 (2.21)	3.19 (0.97)
4 (101.6)	26.70 (1.68)	1.36 (0.42)	37.8 (2.38)	1.93 (0.59)	53.4 (3.37)	2.73 (0.83)	75.5 (4.76)	3.86 (1.18)
5 (127)	48.3 (3.05)	1.58 (0.48)	68.3 (4.30)	2.23 (0.68)	96.6 (6.10)	3.16 (0.96)	137 (8.64)	4.47 (1.36)
6 (152.4)	78.5 (4.83)	1.78 (0.54)	111 (7.00)	2.52 (0.77)	157 (10)	3.57 (1.09)	222 (14.0)	5.04 (1.54)
8 (203.2)	170 (10.73)	2.17 (0.66)	240 (15.14)	3.07 (0.94)	340 (21.5)	4.34 (1.32)	480 (30.3)	6.13 (1.87)
10 (256)	308 (19.43)	2.52 (0.77)	436 (27.50)	3.56 (1.09)	616 (38.9)	5.04 (1.54)	872 (55.0)	7.12 (2.17)
12 (304.8)	500 (31.55)	2.83 (0.86)	707 (44.60)	4.01 (1.22)	999 (63.0)	5.67 (1.73)	1,413 (89.15)	8.02 (2.45)

a. n = Manning coefficient, which varies with the roughness of the pipe.
 For full flow: Multiply discharge by 2.
 For full flow: Multiply velocity by 1.
 For smoother pipe: Multiply discharge and velocity by 0.015 and divide by n of another pipe.

Remember that fluid must be carried away typically by pipes. If you assume your pipes can handle 100 gallons per minute (GPM) it is of no use to install a trench drain that can handle 400 GPM as the drainage pipes can only handle 100 GPM. Be certain your drainage piping system can handle the expected load.

For more visit www.TDCoA.org and go to "Trench Drain Talk"

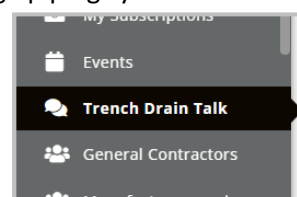

If you have any questions, please email us at the following address: wbonafe@TDCoA.org

TRENCH DRAIN BUZZ

12/31/2021 - A Bi-Annual Newsletter by Trench Drain Contractors of America (www.TDCoA.org)

Are on-line sales a good idea?

The goal of any good sales organization is to generate relationships. A good relationship engenders trust. Can this be duplicated on-line rather than in person? That is the question.

The answer for me depends on the product in question, however, screw me once as the saying goes stays in place whether there is an on-line or in person relationship. Regardless of the relationship, good service is key. As we support a shift to on-line sales, we will list some pro's:

- Service to all 48 contiguous states can be provided.
- Can provide quick responses.
- Wasted time for engineer/designer is eliminated.
- Quick responses to requests for quotes by contractors can be provided.
- Videos can be provided making dog & pony shows unnecessary.

Email us at wbonafe@TDCoA.org with comments

By Wes Bonafe' P.E.



To slope or not to slope

Portions of this article were taken from an article published by MIFAB (TD-2015)

As we begin this conversation we agree: Neutral = neutral slope = no slope = flat.

There is an ongoing difference in behavior. It has been the custom in the United States and Canada to specify trench drain systems that have pre-sloped bodies under the assumption that pre-sloped trench drains will provide a greater flow of fluid due to the sloped sections. After all, drainage pipes are required by code to be sloped. Like many things in today's world, this custom has been accepted as the common practice. In contrast, for decades specifiers in Europe specified flat trench drains as their standard design because flat trench drain systems perform just as well (if not better) than sloped trench drain systems.

If you have any questions, please email us at the following address: wbonafe@TDCoA.org



12/31/2021 - A Bi-Annual Newsletter by Trench Drain Contractors of America (www.TDCoA.org)

There are advantages to the specifier, building owner, contractor, and wholesaler to using flat trench drain systems. Some advantages are:

1. *Faster delivery to the jobsite as fewer sizes of trench drain channels are needed.*
2. *No chance of installing the incorrect trench drain channel in the proper numerical sloped order of the system.*
3. *Faster installation preparation because one size trench drain channel does not require complicated site organization.*
4. *Faster installation due to same height of the trench drain channel. Often, sloped trench drain channels are mixed on a pallet requiring time to sort & identify them. This is not the case with flat channels.*
5. *Increased flexibility because the contractor can easily increase the number of flat drain channels to extend or replace a run. This is not possible with sloped trench drain channels.*
6. *Lower overall cost to the building owner.*

The flow rate of a trench drain is affected by five main factors:

1. *The height of the channel.*
2. *The width of the channel.*
3. *The length of the run.*
4. *The number and size of pipes draining fluid away from the trench drain.*
5. *The flow rate capacity of the grates on top of the channel.*

For this article we are mainly concerned with the first one. Trench drain channels with a greater height (assuming the width is the same) have more volume capacity and therefore a greater flow rate because the head pressure is greater when the fluid height is higher.

A typical sloped trench drain system (refer to Figures 1-A and 2-A on the following page) starts off with a shallow sloped channel section and ends with a deeper sloped channel section. This means that the channel height is not consistent, and the volume capacity of the sloped system is less than the volume capacity of a flat system that has the same channel height throughout the run (refer to Figures 1-B and 2-B on the following page).

Figures 1-A and 2-A illustrate a typical sloped trench drain system with flow rates of 98.27 GPM in the 10-meter run and 142.60 GPM in the 20-meter run. Figures 1-B and 2-B illustrate a flat trench drain system with flow rates of 99.20 GPM in the 10-meter run and 149.80 GPM in the 20-meter run. Note that the ending internal channel heights in a typical sloped trench drain is the same as all channel heights in the flat systems.

Therefore, take advantage of the greater flow rates and easier installation of the flat trench drain systems instead of specifying sloped trench drain systems.

If you have any questions, please email us at the following address: wbonafe@TDCoA.org



12/31/2021 - A Bi-Annual Newsletter by Trench Drain Contractors of America (www.TDCoA.org)

6" Wide Sloped vs Flat Flow Rate Comparison

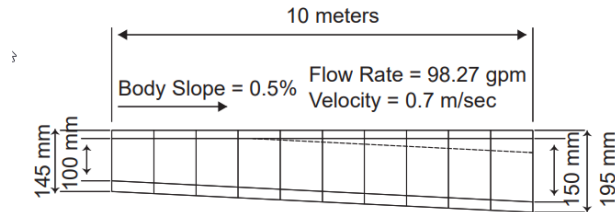

Figure 1-A Typical Sloped Trench Drain

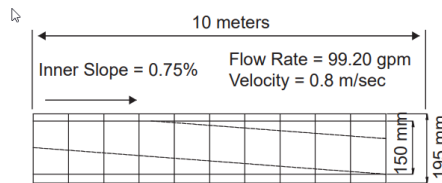

Figure 1-B Typical Flat Trench Drain

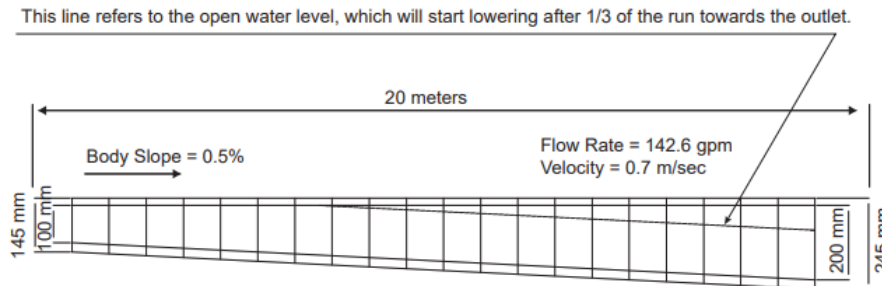

Figure 2-A Typical Sloped Trench Drain

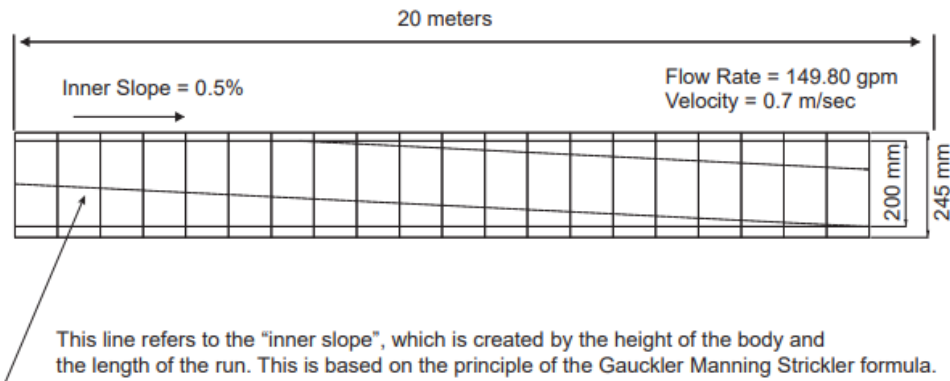

Figure 2-B Typical Flat Trench Drain

NOTE:

A flat run with consistent height bodies will always have a higher flow rate because total trench drain volume will be higher than a sloped system. A substantial increase in flow rate can only be achieved in a sloped system that has a slope of more than 1.6%. Note that sloped bodies available typically have a body slope of only 0.5% to 0.6%

If you have any questions, please email us at the following address: wbonafe@TDCoA.org

MOST MAJOR MANUFACTURERS

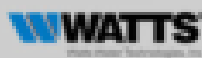

Warehouses in: Norfolk Virginia and Las Vegas Nevada
Serving the Contiguous 48 States



YOUR TRENCH DRAIN SOURCE